

BUILD-AN-ORIGAMI BEAR

STEP 1:
Fold paper in half

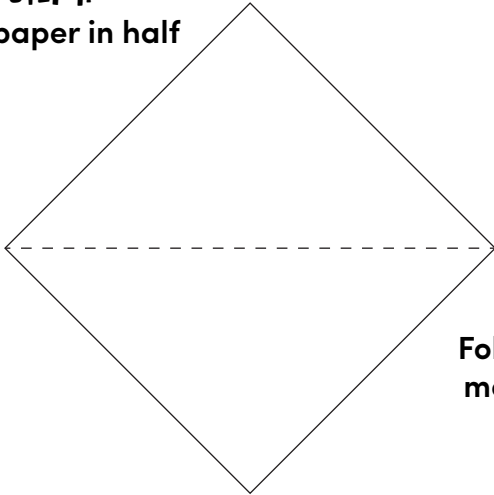

STEP 2:
Fold in half again to
make a crease and
fold back

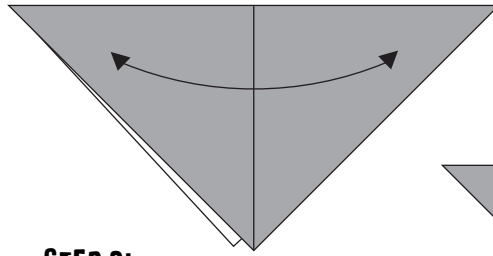

STEP 3:
Fold the corners in
slightly past the middle
crease as shown

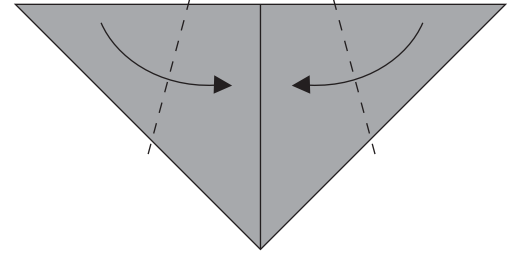

STEP 4:
Fold back corners as shown,
leaving about a half-inch on
each creased piece

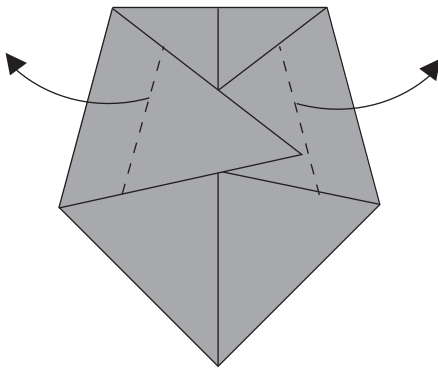

STEP 5:
Fold the small outer
tips in by 1/4 inch

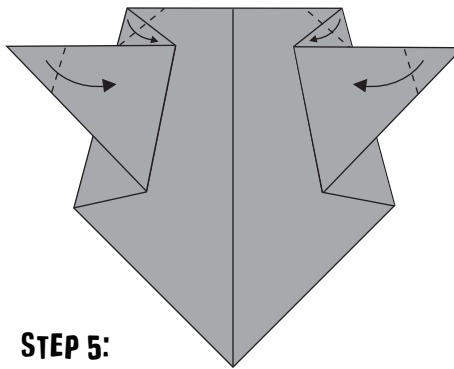

STEP 6:
Turn over

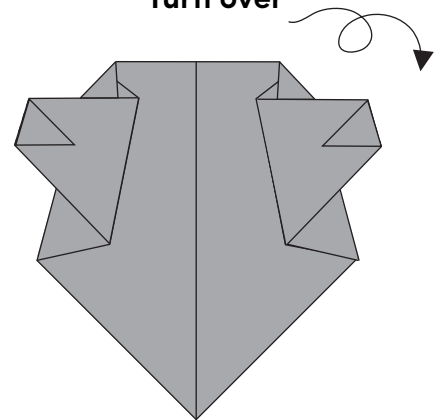

STEP 7:
Fold bottom flap
up as shown

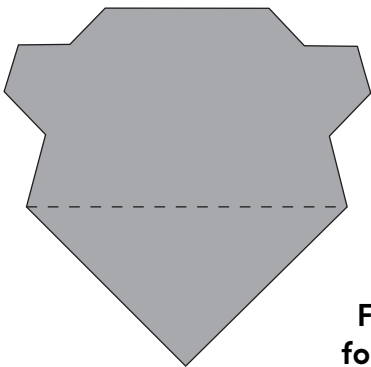

STEP 8:
Fold tip of back flap back,
fold tip of front flap forward
as shown

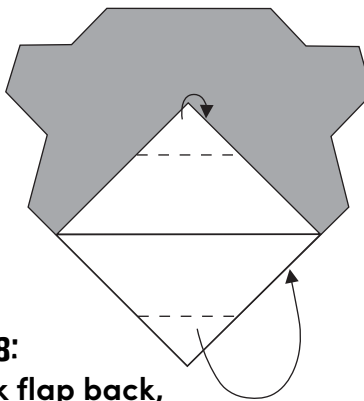

STEP 9:
Draw a face on
the finished bear

